

ketta-6

a chain of six volumes that float kite-like, winding sculpturally in space. The overall form of the piece can be altered in dramatic ways and, like a kaleidoscope, the geometry changes shape from different viewpoints.

The individual units of ketta were conceived as fabric covered volumes functioning like a photographer's softbox and providing a warm diffuse light. The introduction of custom color choices to each of the four sides presents designers with opportunities to tailor the piece to a variety of interior settings.

ketta is a very adaptable fixture and ideally suited for larger spaces. Since it can be shaped freely and hung in any position, it provides designers with an opportunity to define space in unique ways. To facilitate the design process, we have specifications and CAD models available that define a number of configurations and suspension details.



dimensions.....	a range of sizes are possible, please see dimensions for some positions in the accompanying pages
material.....	structure of aluminum or brass with a shell made of plastic film covered by fabric
finish.....	satin or brushed anodized aluminum or brass
lamping.....	(6) 9w LED Bridgelux Vero, 2700K or 3000K
power.....	120-240V electronic dimmable transformer
suspension.....	(4) aircraft cables. (5)ft of cable is stored in the movable suspension points and can be adjusted in length as necessary during positioning
pricing.....	list \$14500, net \$11600 as shown in anodized aluminum

ketta can be fixed in many positions. The following sheets show the dimensions of four of them.

Position 6.1

As with all positions for the fixture, there is no required orientation.

elev or plan

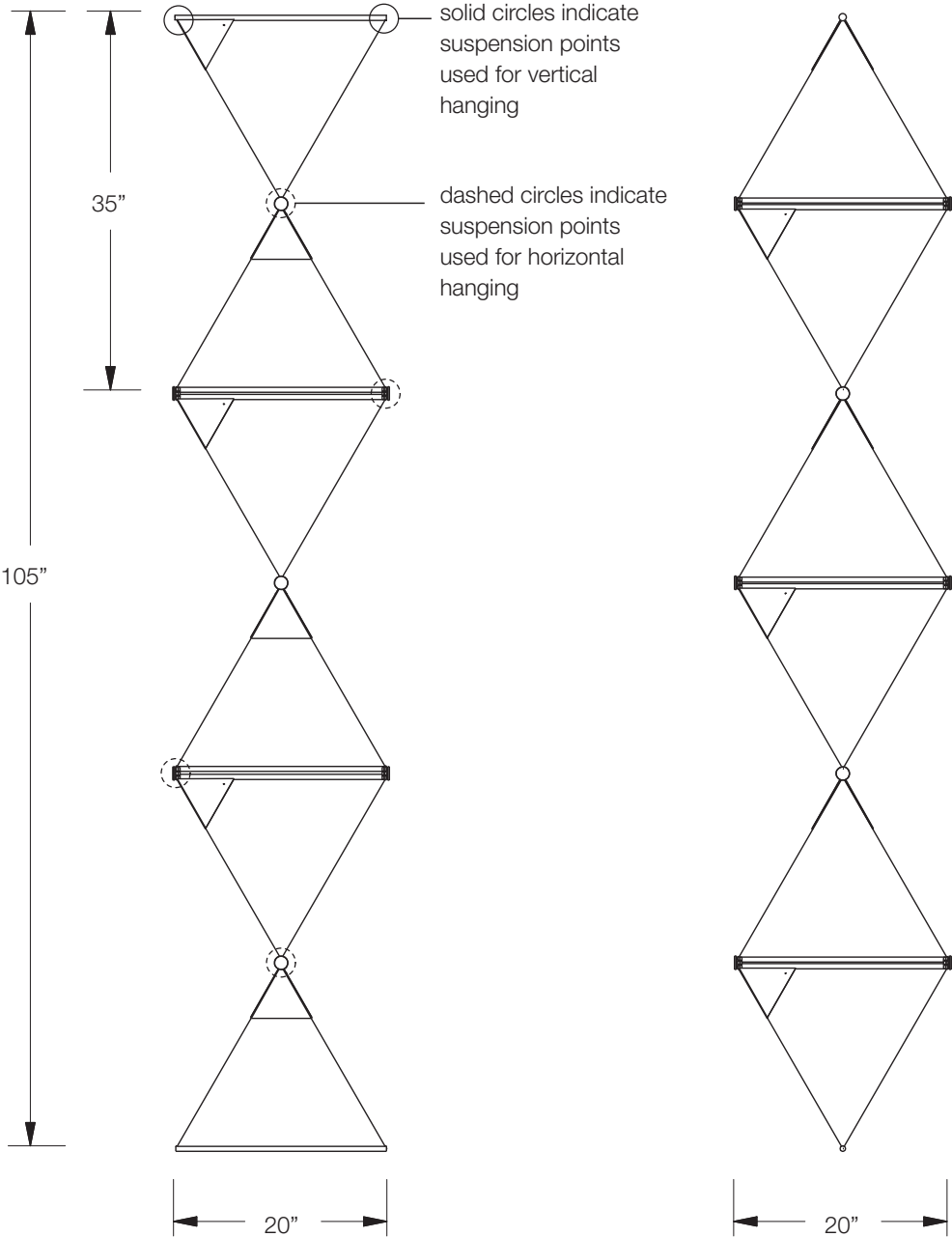

Position 6.2

As with all positions for the fixture, there is no required orientation.

plan

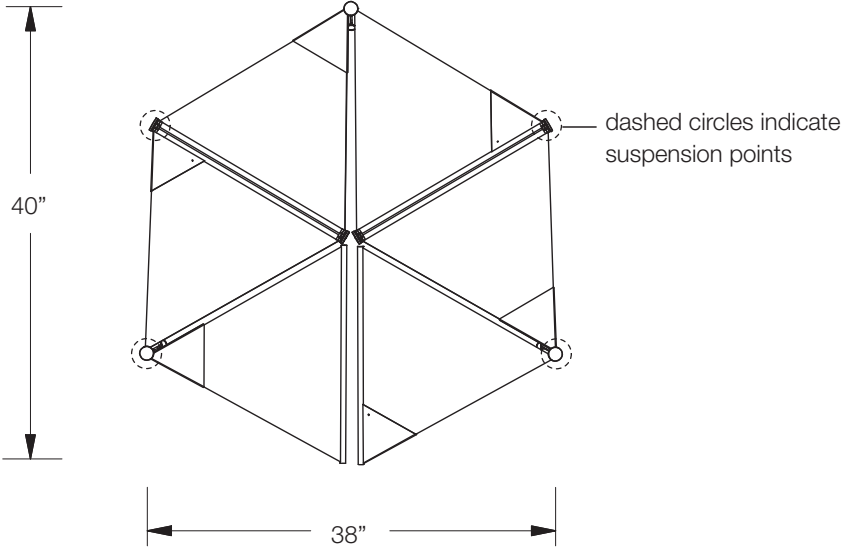

elev

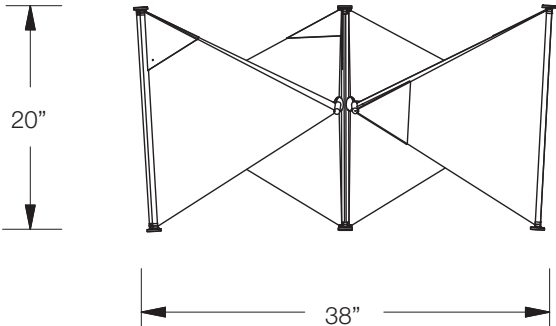

Position 6.3

For arrangements that are long and horizontal, suspension points can be directly in the ceiling or from an adjustable mount. As with all positions for the fixture, there is no required orientation.

plan

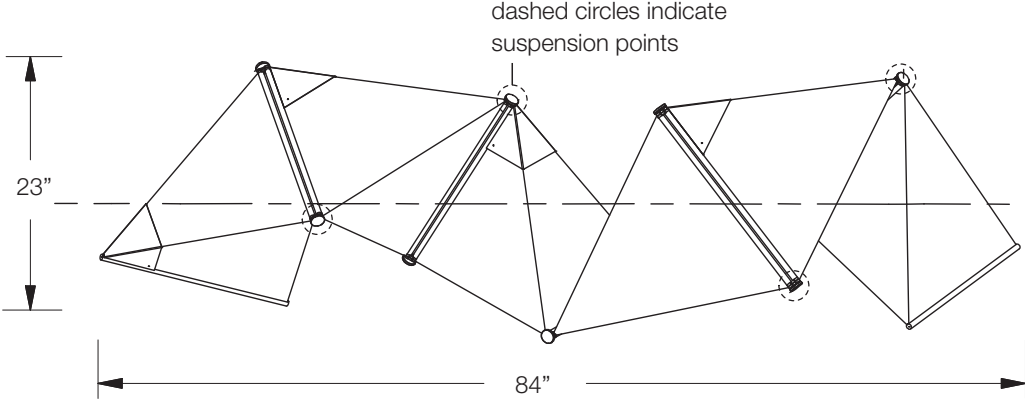

elev

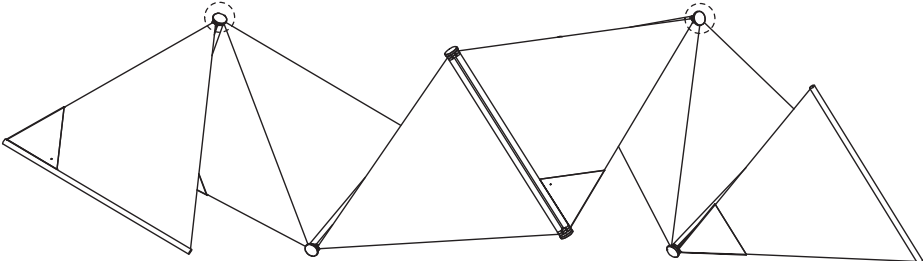

suspension layout for this arrangement

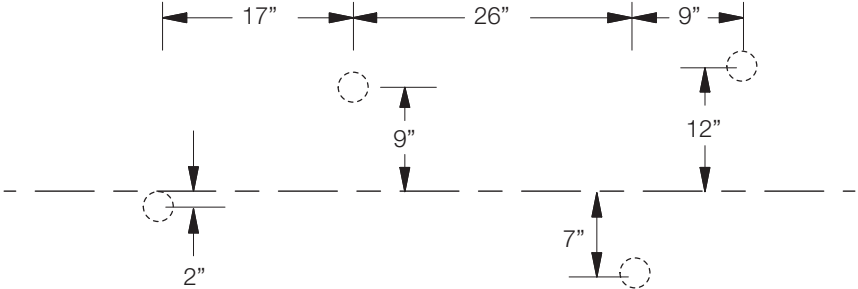

Position 6.4

For vertical arrangements, ketta suspends from four cables in a ceiling canopy.
As with all positions for the fixture, there is no required orientation.

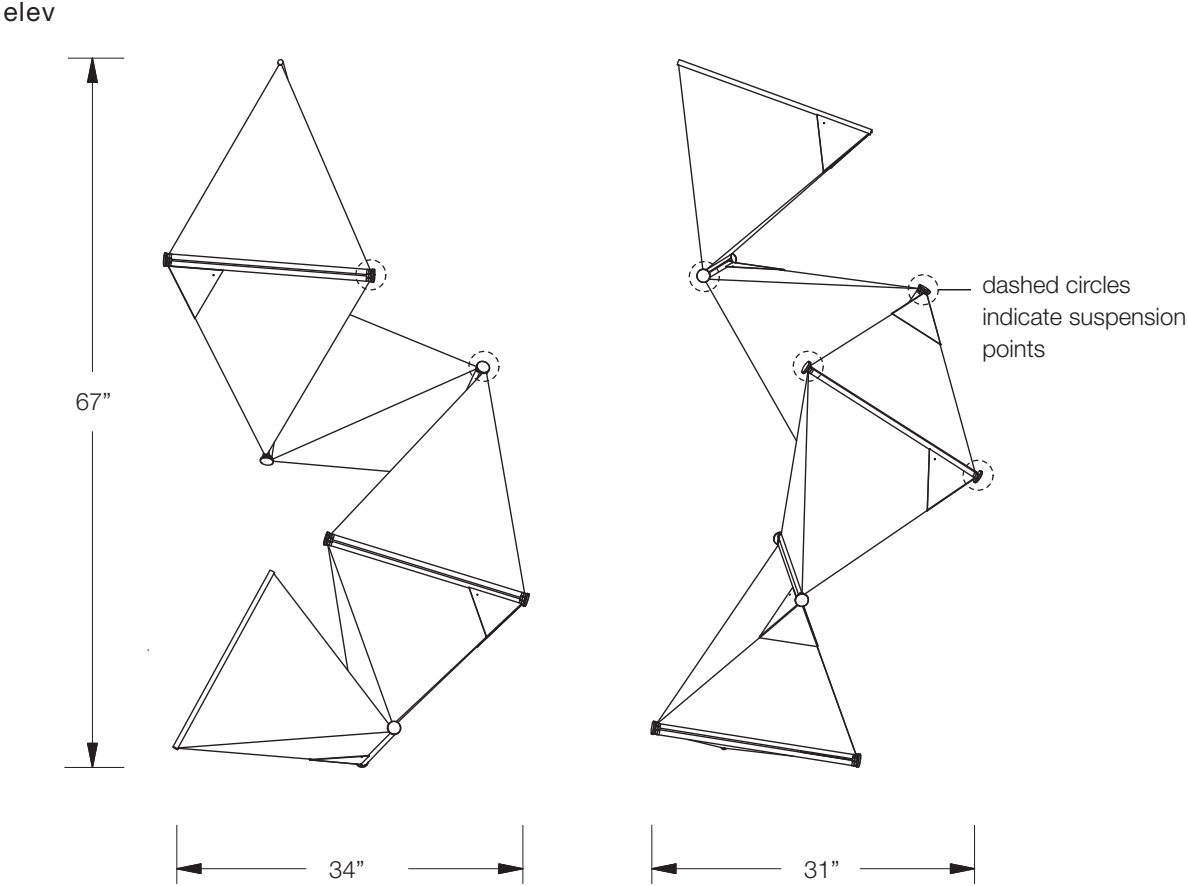

plan

suspension layout for this arrangement

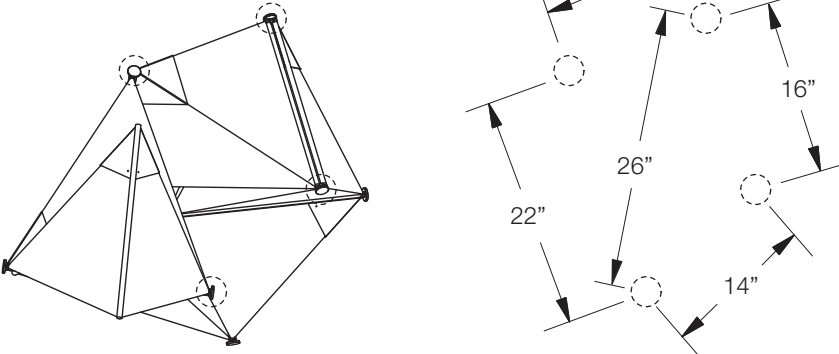

The fabrics used on the surfaces of ketta are from Maharam - www.maharam.com. We use four lines; Air, Noon, Fillippa and Campas, shown below. All samples can be seen in finer detail on their website.

Air and Noon are very sheer fabrics, so the colors will be less vibrant when lit, but allow for more light transmission than the Fillippa (more dense) and Campas (most dense). Since the side of each ketta unit opposite the light source provides the majority of illumination, we recommend that this side be a white or off-white Air fabric. The remaining three sides can be a mix of any of the fabrics.

air

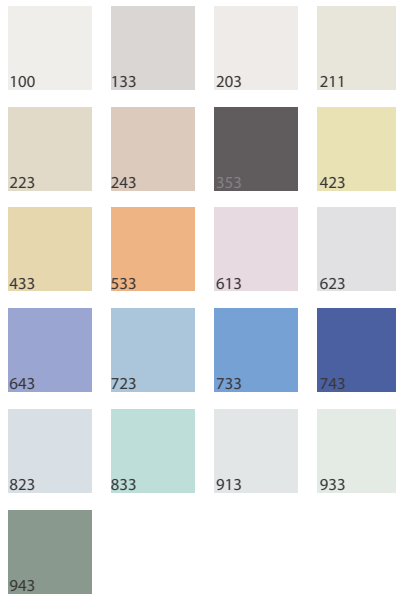

noon

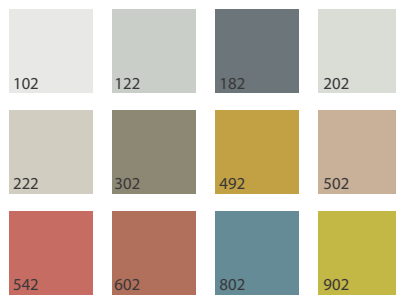

fillippa

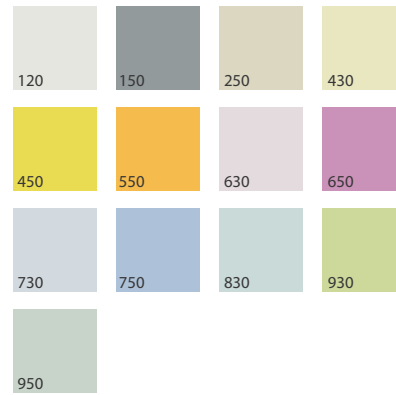

campas

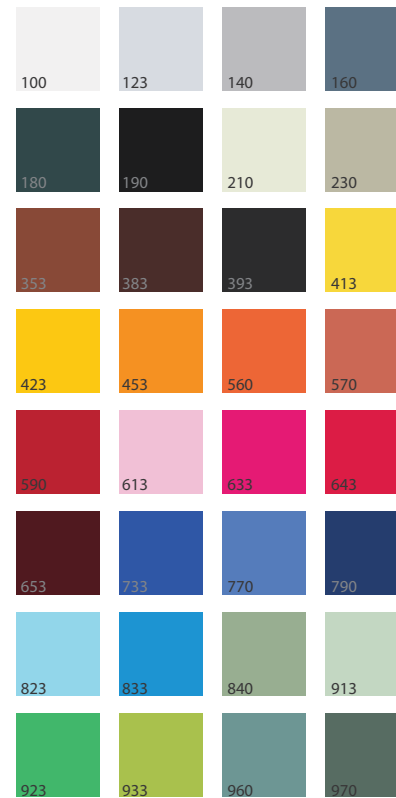

Monochrome gray palette
This colorway illustrates a monochrome palette of two colors and white in a repeating pattern. Any substitution or addition is possible.

air

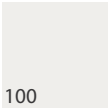

noon



fillippa



sides 1 and 2

sides 3 and 4

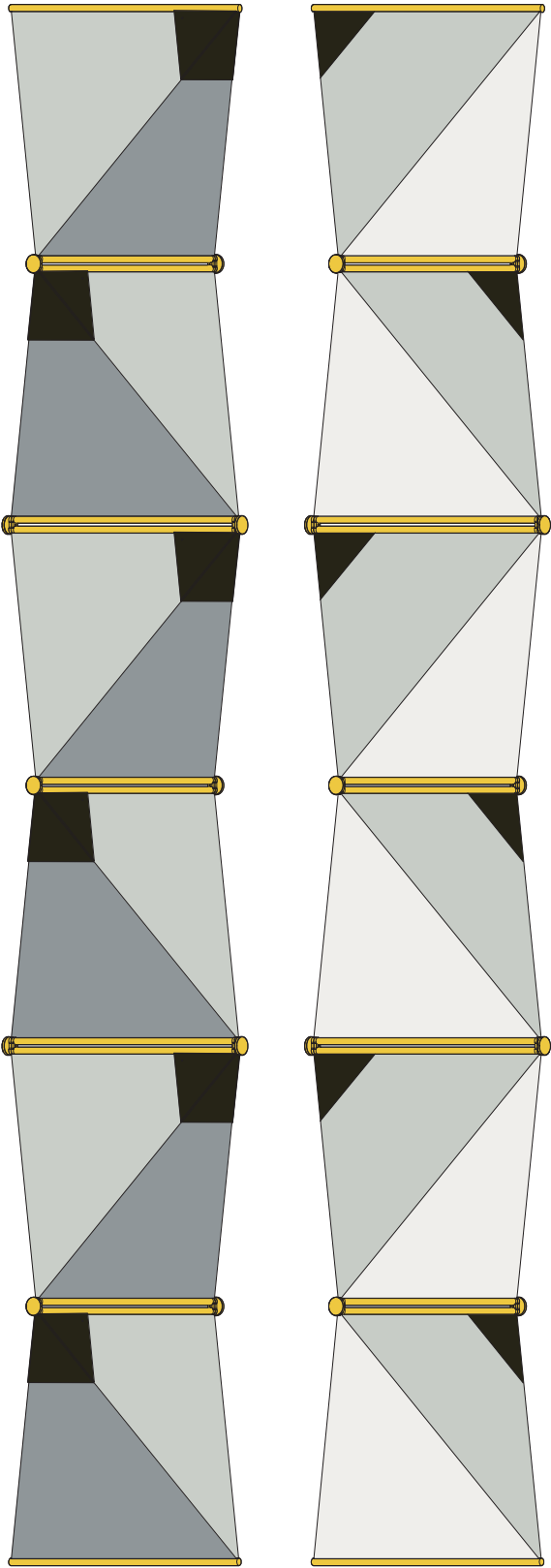

Monochrome warm palette
This colorway illustrates a monochrome palette of five colors and white in a semi-repeating pattern. Any substitution or addition is possible.

air

	
100	223

noon

	
222	302

campas

	
230	393

sides 1 and 2

sides 3 and 4

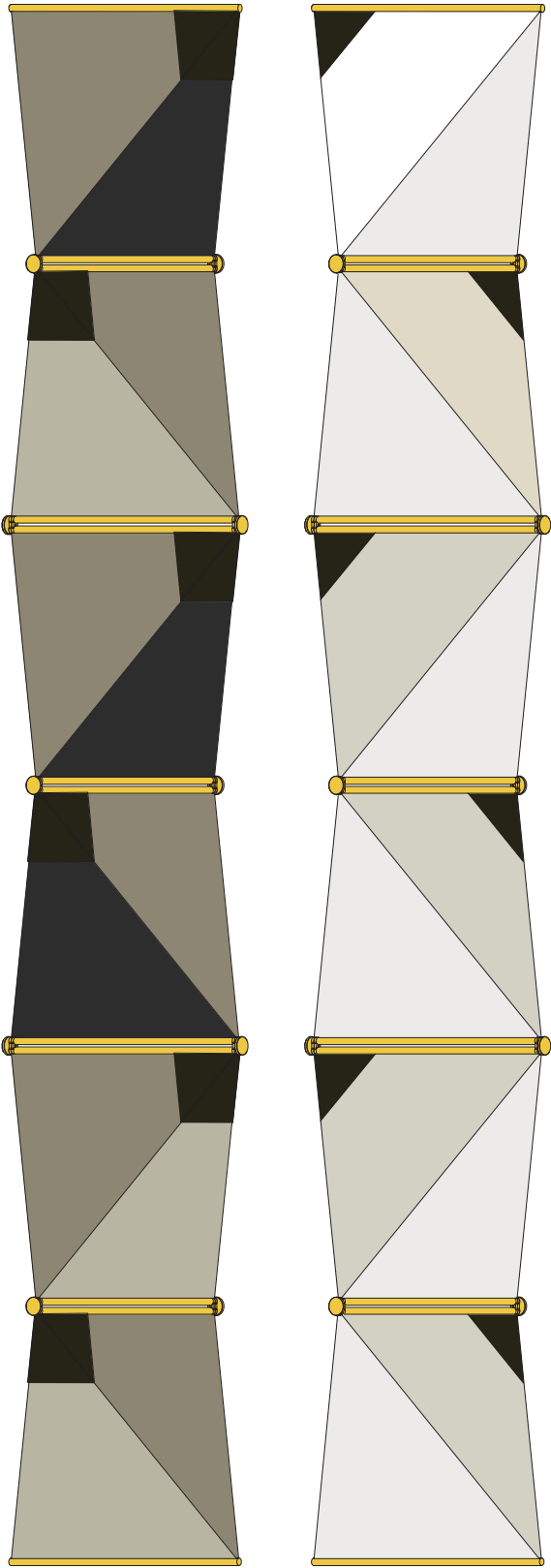

Neutral palette
This colorway illustrates a mixed palette of nine colors and white using a subdued range of hues. Any substitution or addition is possible.

air



noon



fillippa



campas



sides 1 and 2

sides 3 and 4

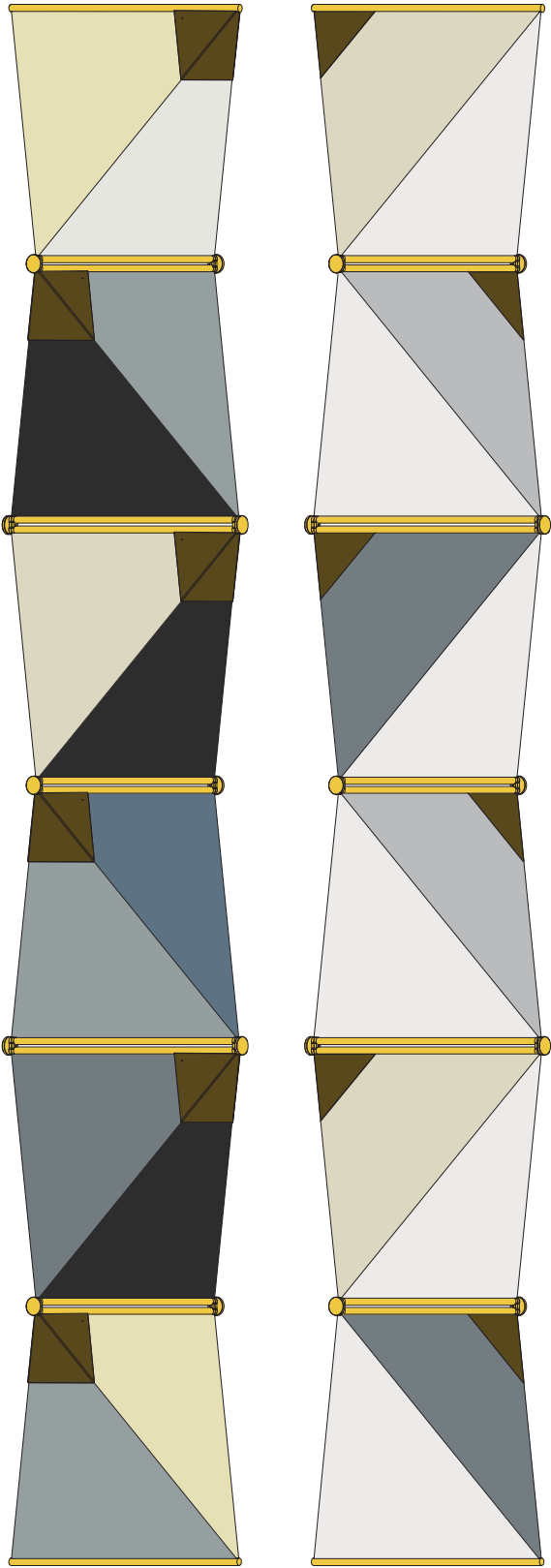

Narrow color palette
This colorway illustrates a mixed palette of seven colors and white with regular use of bold color. Any substitution or addition is possible.

air

100 423

noon

122 202

fillippa

430 830

campas

423 643

sides 1 and 2

sides 3 and 4

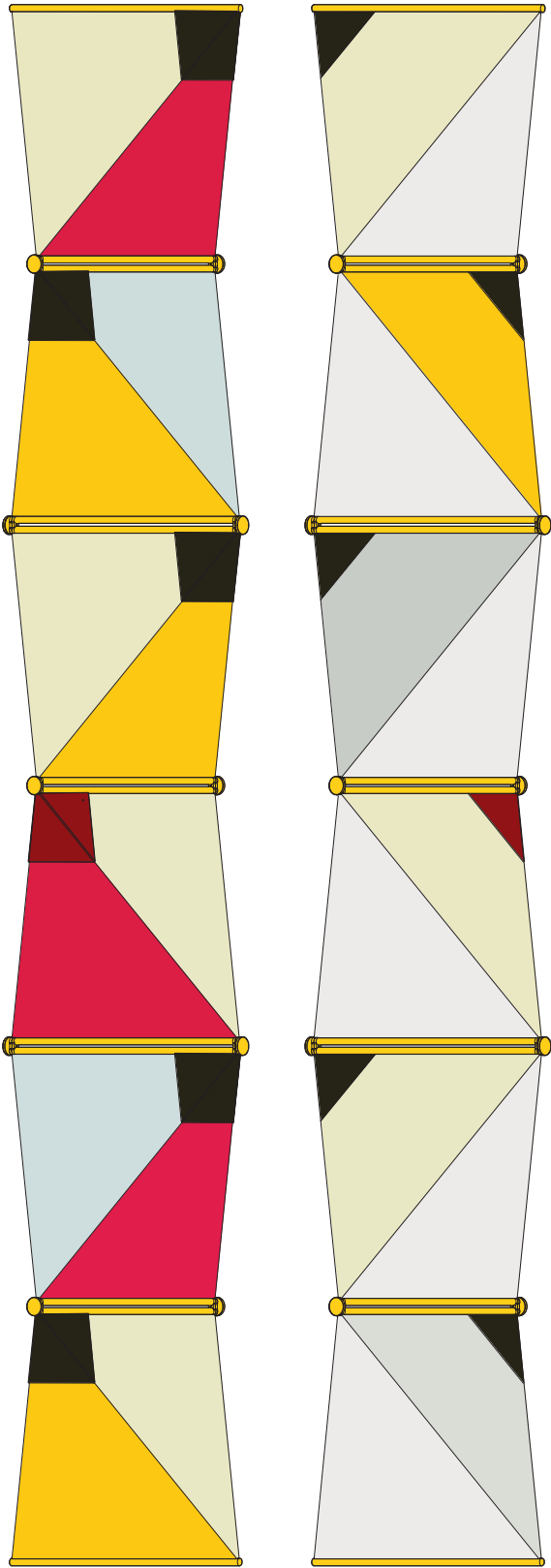

Broad color palette

This colorway illustrates a mixed palette of twelve colors and white with broad mix of bold colors. This is the same set of colors as in the image on page one. Any substitution or addition is possible.

air

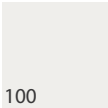

noon



fillippa

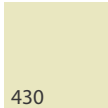

campas

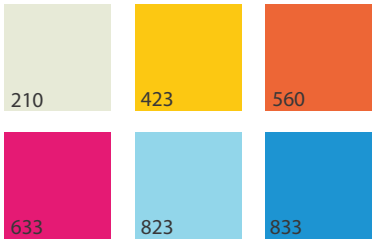

florentijn

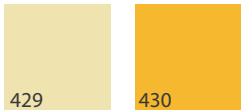

sides 1 and 2

sides 3 and 4

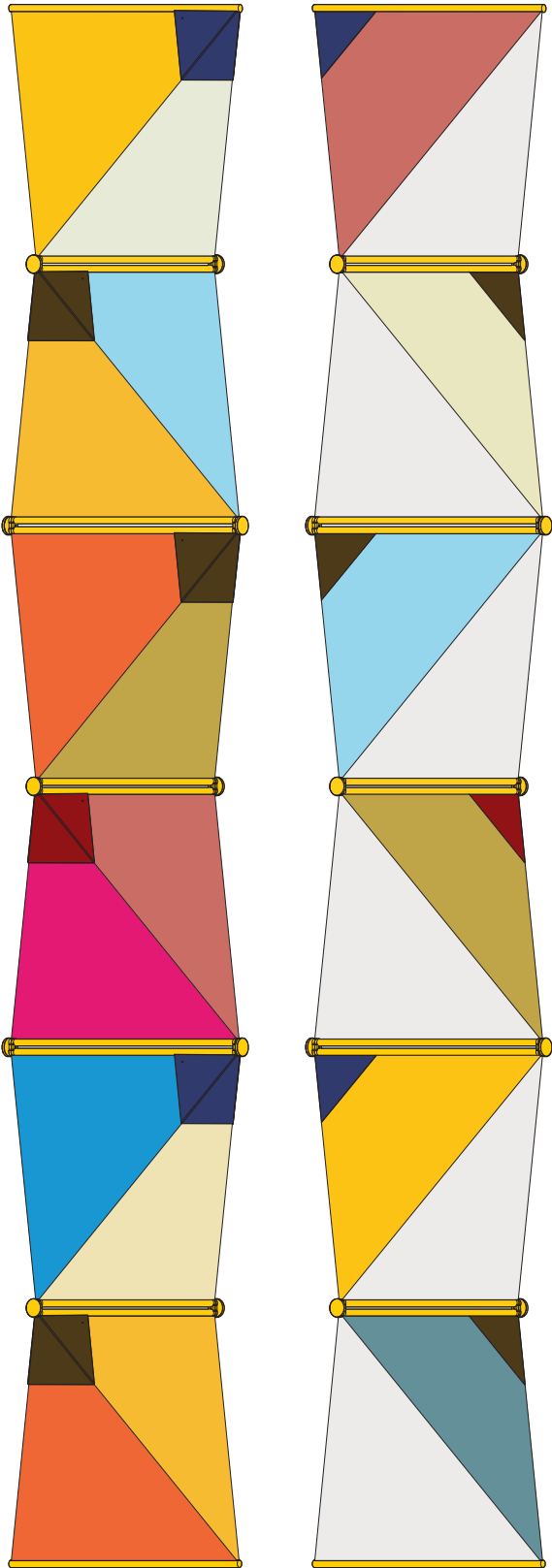

Contrast color palette
This colorway illustrates a mixed palette of ten colors and white with an emphasis on contrast.
Any substitution or addition is possible.

air

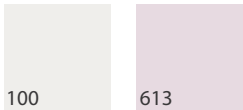

noon



fillippa

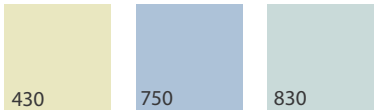

campas

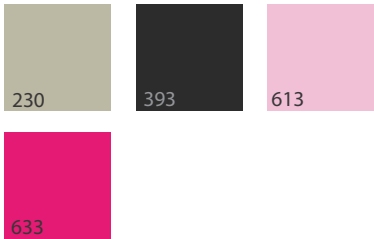

sides 1 and 2

sides 3 and 4

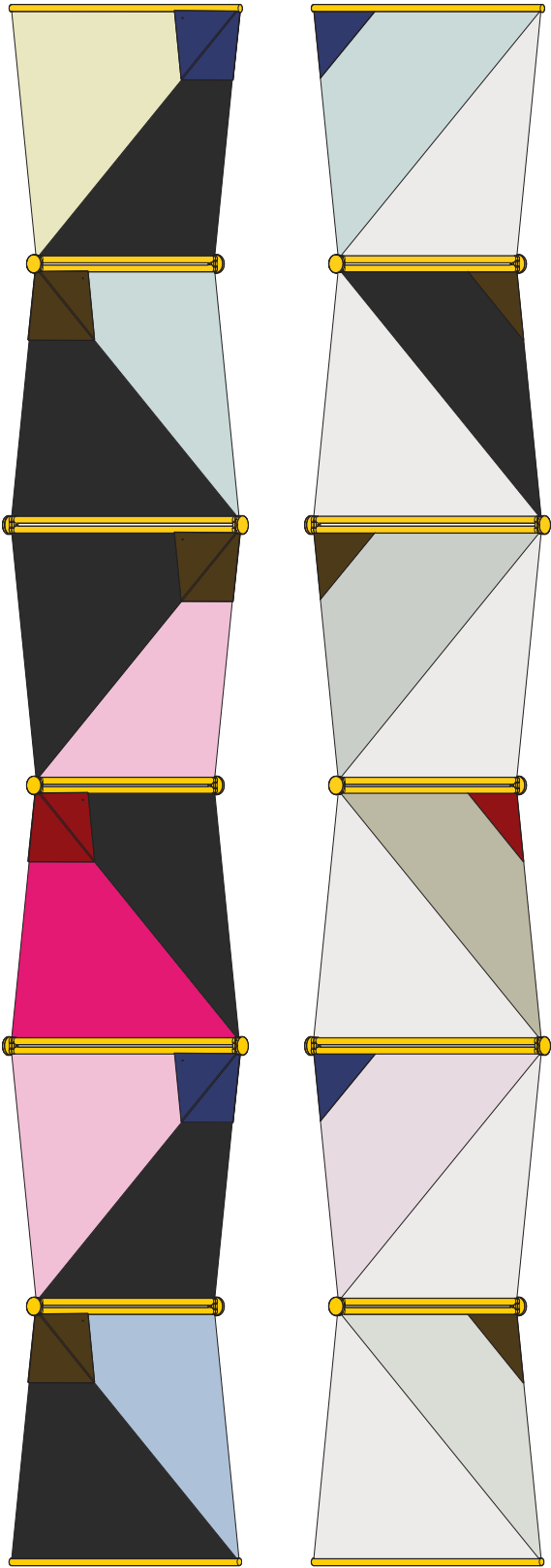

Warm neutral palette
Brass hardware
This colorway illustrates a monochrome palette of five colors and white in a semi-repeating pattern. Any substitution or addition is possible.



sides 1 and 2

sides 3 and 4

